

# DUAL MOUNTING OF DISC WHEELS

## STUD LENGTH IS CRITICAL

### Aluminum Wheel Mounting-Inboard Drum

Show below in figure 1 is the correct mounting of aluminum disc wheels. Note the length of the stud extending through the outer wheel giving it the necessary support. Illustrated in figure 2 is the incorrect mounting of aluminum wheels. The stud used on this application is too short, causing the outer wheel to be insufficiently supported.

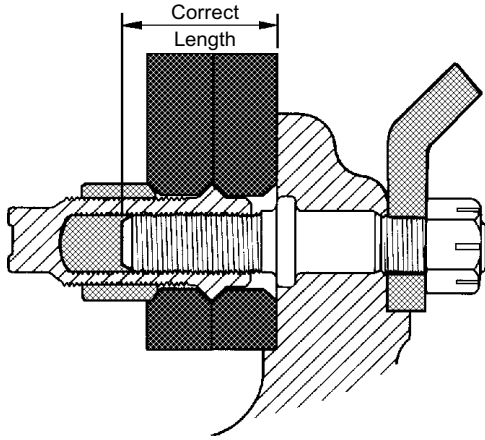

Figure 1  
**CORRECT**

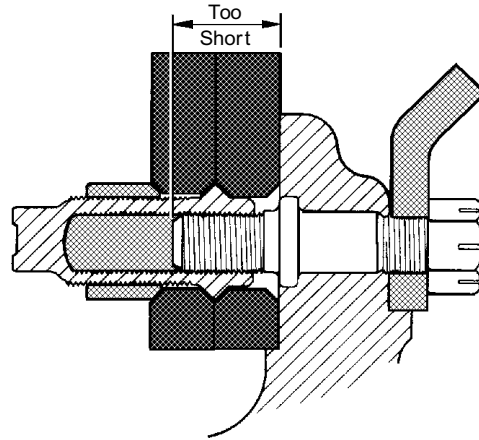

Figure 2  
**INCORRECT**

W486 and W487 are counter-bored 5/16" at the opening to prevent the non-threaded portion of some studs from bottoming out.

### Steel Wheel Mounting-Inboard Drum

The same application principal also applies to steel wheels. Stud stand-out must extend beyond both wheels by at least 5/16" (see figure 3). You must insure that the stud is not too long because it could "bottom out" in the inner nut. This condition (as shown in figure 4) will prevent the inner nut from properly holding the wheel even though the recommended torque procedures were followed.

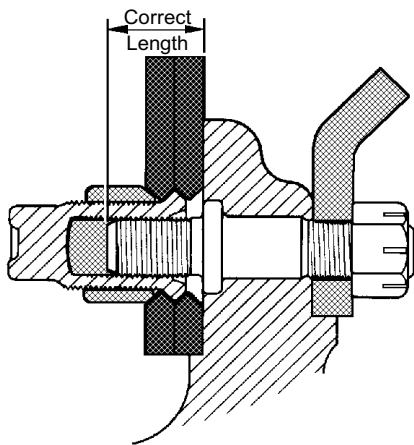

Figure 3  
**CORRECT**

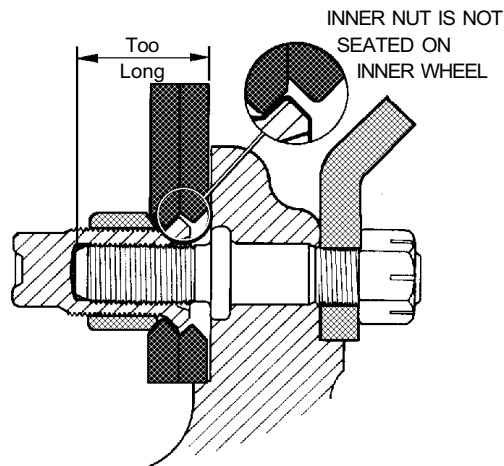

Figure 4  
**INCORRECT**

Wheel  
Mounting

21

# SINGLE WHEEL STUD PILOTED MOUNTING

## Cap Nut Engagement (Aluminum or Steel) Single Wheel-Outboard Drum

Single aluminum or steel wheel cap nuts should be installed flush to the end of the stud with all threads engaged. A few unengaged threads at the external end of the stud are generally acceptable after proper torque is applied. Some state laws specify that two full threads be visible. Consult your state D.O.T. for verification if necessary.

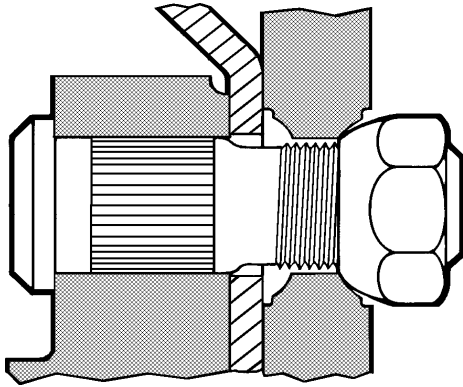

Figure 5  
Correct single mounting with 1-1/8" stud located, ball seat mount.

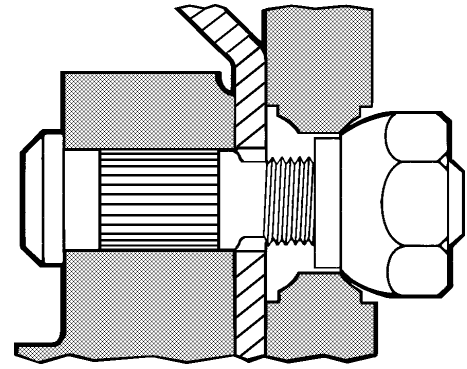
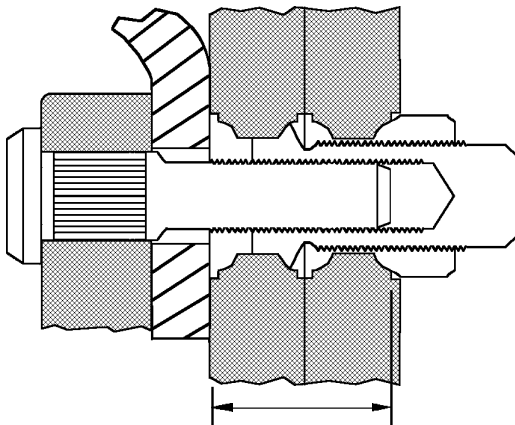

Figure 6  
Correct single mounting with 3/4" stud located, ball seat mount.

## HEADED STUD BALL SEAT MOUNTING

### Ball Seat, Stud Piloted Stand Out For Disc Wheels-Outboard Drum

The standouts shown below are the normal recommended ranges. Some applications for dual aluminum wheels use up to a 1-7/8" stand out. Measure the original stand out for reference before changing drums or wheels. Changing from dual aluminum to dual steel or aluminum/steel combinations will require changing inner nuts and may require changing to studs with a standard 1-5/16" to 1-7/16" stand out.



Dual Aluminum=1-5/16" to 1-7/16"  
Figure 7

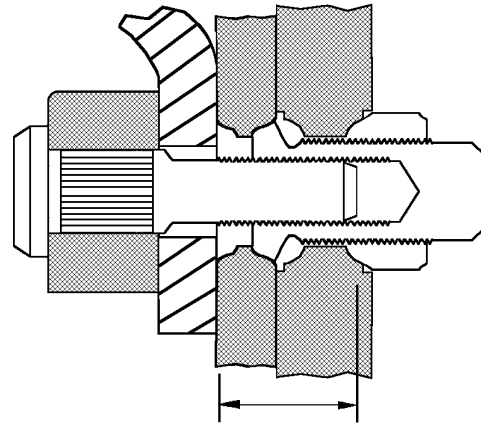

Steel Inner/Aluminum outer=1-5/16" to 1-7/16"  
Figure 8

Wheel  
Mounting

21

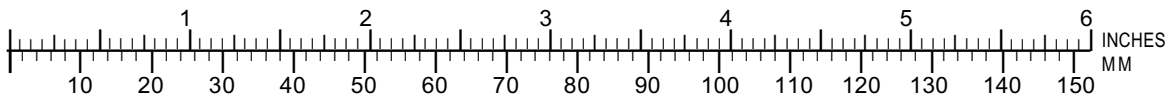

© Copyright 2003 Triangle Suspension Systems, Inc.

475

# HUB PILOTED MOUNTING

## Hub Piloted Wheel Mounting Stand Out Using 2 Piece Flange Nuts, Single, Dual and Wide Base Wheels

Some hubs designed for hub piloted steel wheels do not have sufficient pilot length to locate dual aluminum wheels. A minimum pilot length of 1-1/16" is necessary for safe and proper installation. This should be measured before purchasing aluminum wheels for a conversion.

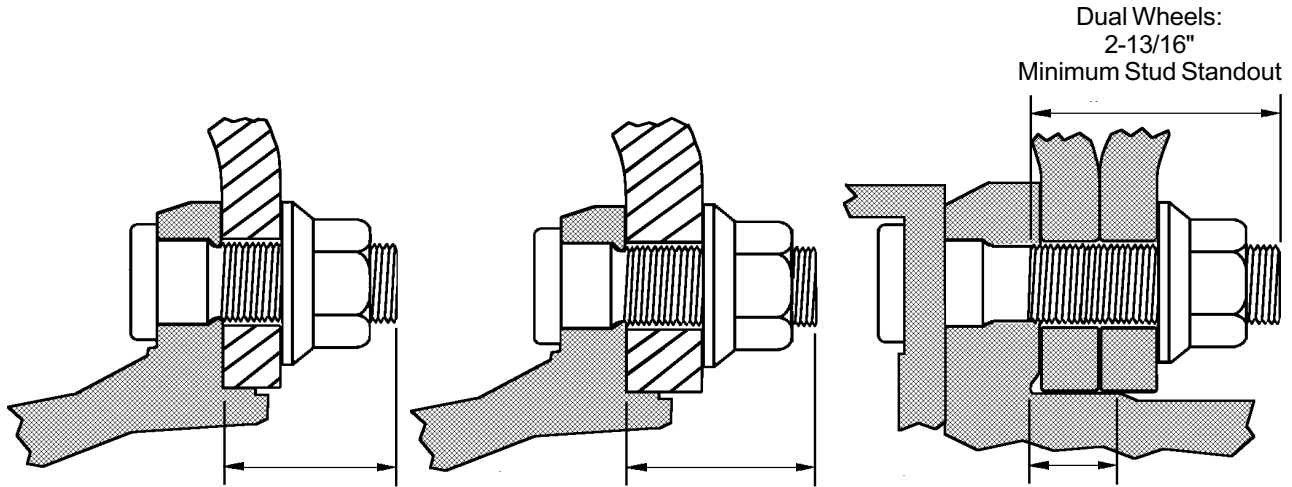

Single Wheel:  
2" Minimum Stud Standout  
Figure 9

Single wide base wheels:  
2-3/8" Minimum Stud Standout  
Figure 10

Dual Wheels:  
2-13/16"  
Minimum Stud Standout  
1-1/16" Minimum Pilot Length  
For dual aluminum wheels  
Figure 11

## INCORRECT MOUNTING

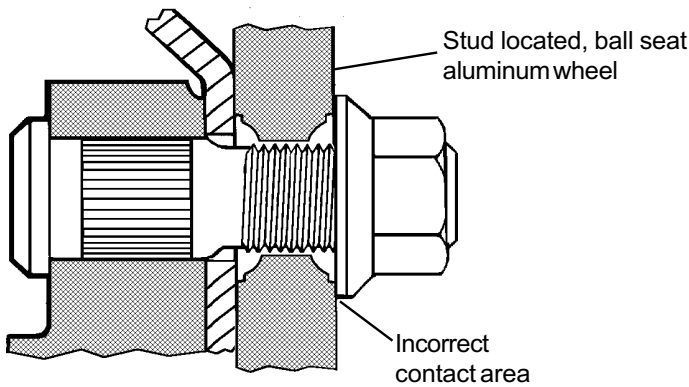

Figure 12  
Incorrect use of two piece flange nut

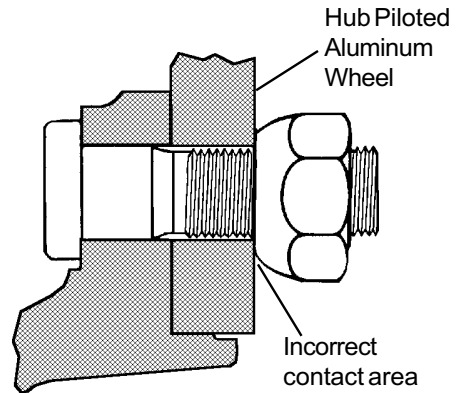

Figure 13  
Incorrect use of ball seat cap nut

Wheel  
Mounting

21